

CAD FILE :

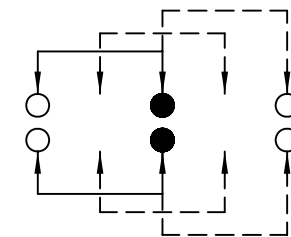

SCHEMATIC (NON-SHORTING)

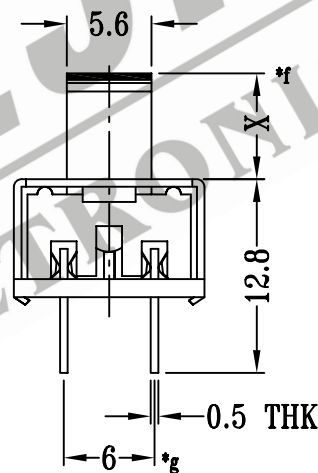
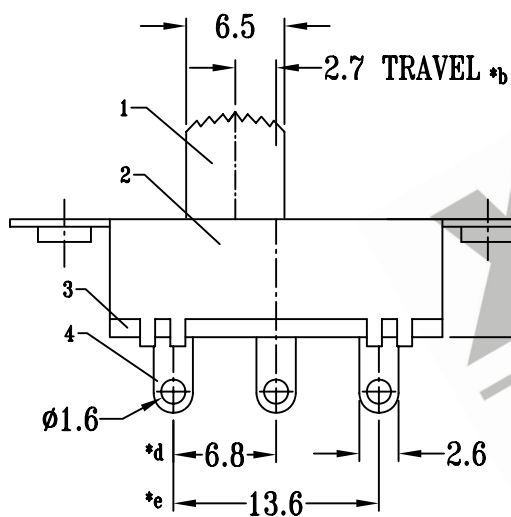
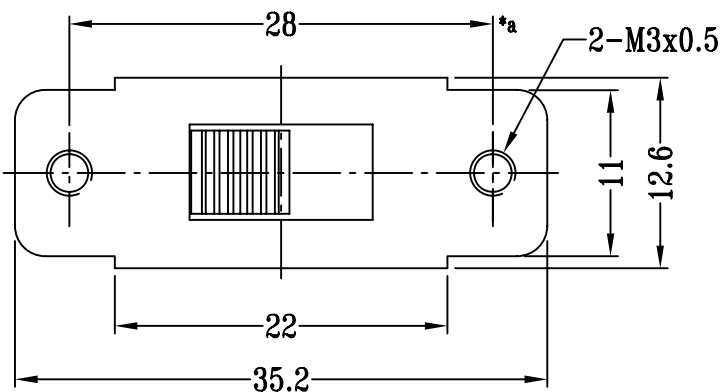
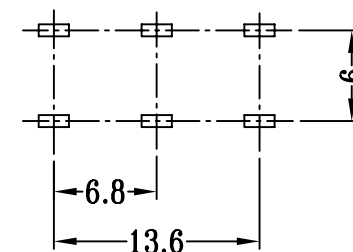

P.C.B LAYOUT

注:带"*"表示关键尺寸(7个)

| | | | | | | | | | | |
|-----|----------------|----------------|------|-----------|---|---------------------------------------|-------------|----------------------------|--------------|-----------|
| 8 | CONTACT CLIP | PBS STRIP | 2 | Ag PLATED | TOLERANCE UNLESS SPECIFIED | SHENZHEN XIEJIA ELECTRONICS CO.,LTD. | | | | |
| 7 | POSITION PLATE | STEEL STRIP | 1 | Ni PLATED | | WITHIN: 1.5±0.1mm OVER : 1.5±0.2mm | ISSUE | DATE | DESCRIPTIONS | |
| 6 | STEEL BALL | STEEL | 1 | NATURAL | TITLE: VERTICAL SLIDE SWITCH | | UNIT : M M | DRWG NO : XJ-DR-SS23E39-00 | | |
| 5 | SPRING | STEEL WIRE | 1 | TEMPER | MODEL: SS-23E39 | | SCALE : 2:1 | DWN. | ZHOUYU | 2006-7-10 |
| 4 | TERMINAL | BRASS STRIP | 6 | Ag PLATED | ALL MATERIALS MUST BE COMPLIANT TO ROHS | | | CHK'D | FANGYING | 2006-7-10 |
| 3 | TERMINAL BASE | PHENOLIC RESIN | 1 | BLACK | | | | APPD. | KANGXINAN | 2006-7-10 |
| 2 | FRAME | STEEL STRIP | 1 | Zn PLATED | | | | | | |
| 1 | KNOB | PC | 1 | BLACK | | | | | | |
| NO. | PART NAME | MATERIAL | QTY. | FINISHING | | | | | | |